

Standard Knapp Standard Knapp

an EMPLOYEE owned company

DISCHARGE ROLLER ASSEMBLY

**UPGRADE FOR:
939 Case Packer**

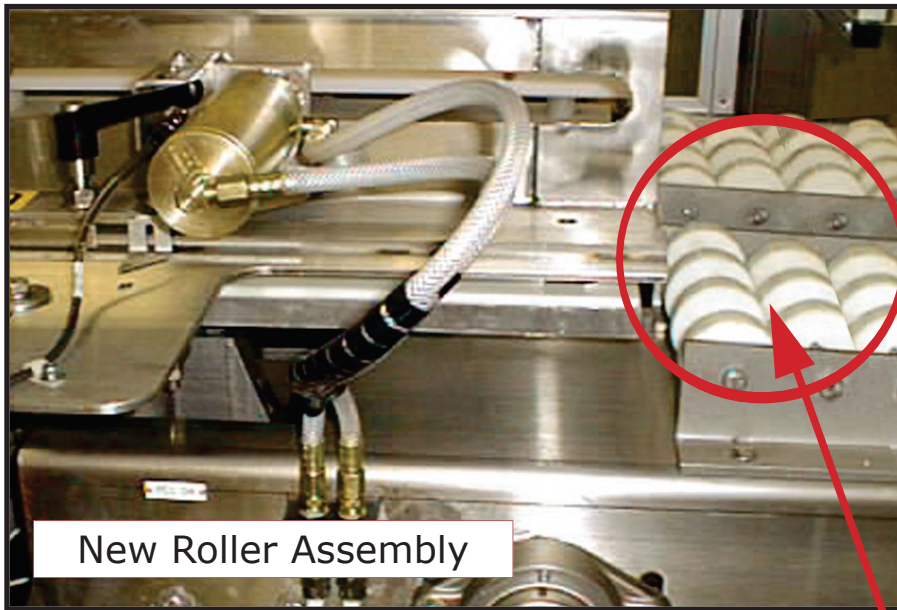

Figure 1.1 - New Multi-Roller Assembly Installed on Machine

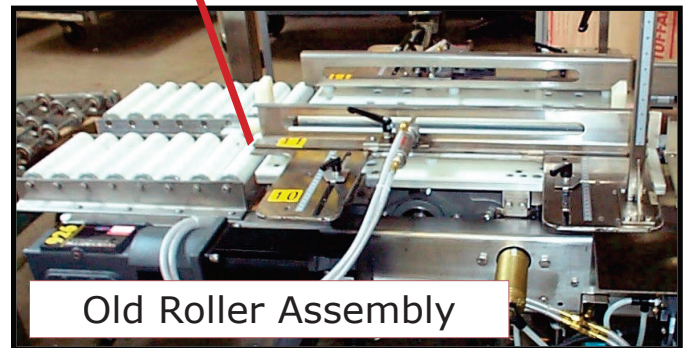

Figure 1.2 - Close-up of Old Style Single Roller Assembly

Benefits

- Long-lasting, consistent operation.
- Easy to install and maintain.
- Reduces machine downtime.
- Virtually eliminates roller failure.
- Increases machine efficiency.

Call Standard-Knapp 1-800-628-9565 for ordering.

Standard-Knapp, Inc.
127 Main Street
Portland, CT 06480
1-800-628-9565
(fax) 860-342-0783
www.standard-knapp.com
info@standard-knapp.com

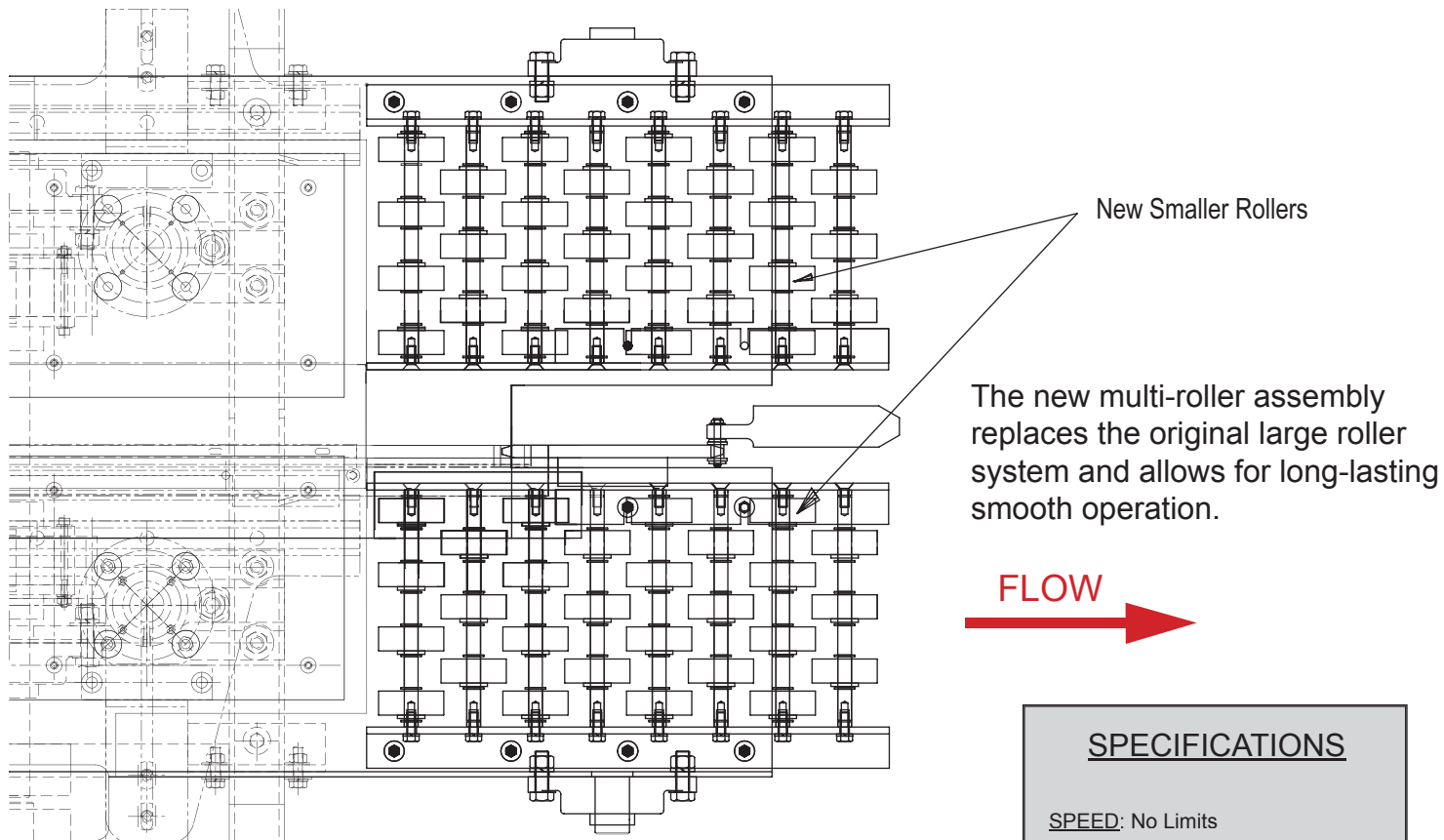

Figure 1.3 - Top View of the new Multi-Roller Assembly

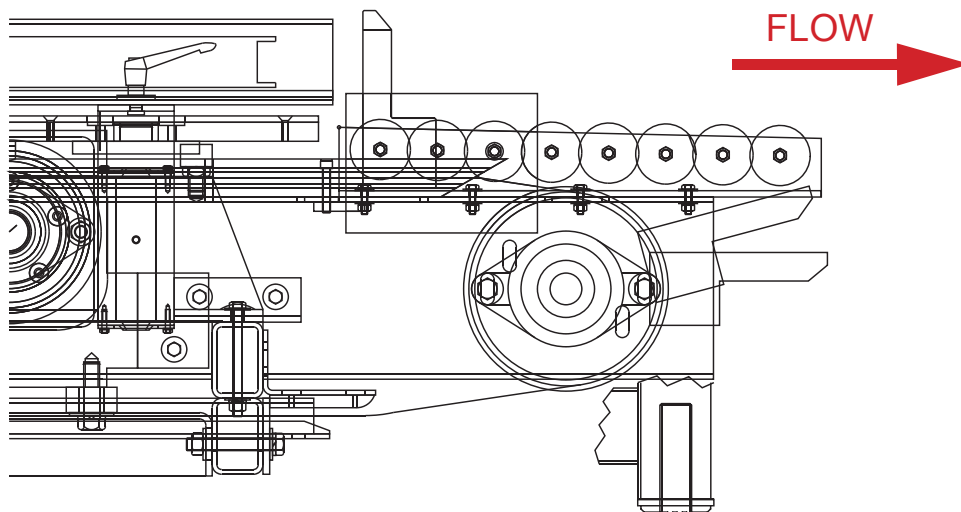

Figure 1.4 - Side View of the new Multi-Roller Assembly

ADDITIONAL UPGRADE KITS AVAILABLE FOR YOUR 939 CASE PACKER

- AIR HOSE MANIFOLD
- IMPROVED INFEED CASE STOPS
- LIFT TABLE REAR CASE CLAMP