

StandardKnapp StandardKnapp

an EMPLOYEE owned company

TRAY BLANK INDEXER

**UPGRADE FOR:
Model 296 Continuum
Traypacker**

Benefits

- Helps reduce double tray pulls and offers increased reliability when working with warped corrugated.
- Improved handling of large tray blanks.
- Positively indexes tray blanks one at a time.
- Easily adjustable to work with all tray blank sizes.

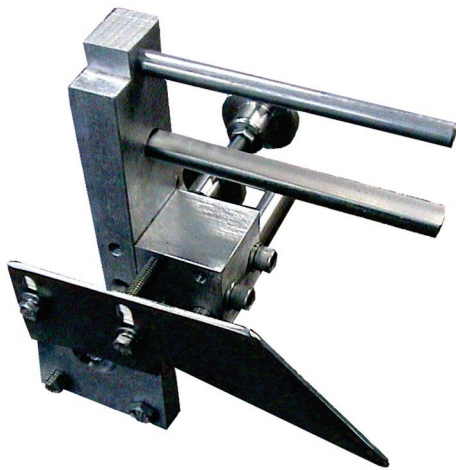

Figure 1.1 - Tray Blank Indexer (Two(2) required)

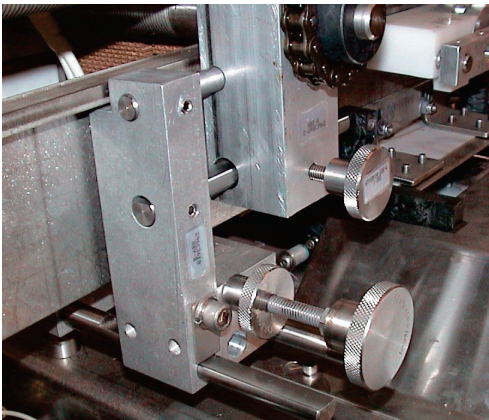

Figure 1.2 - Tray Blank Indexer mounted on Machine

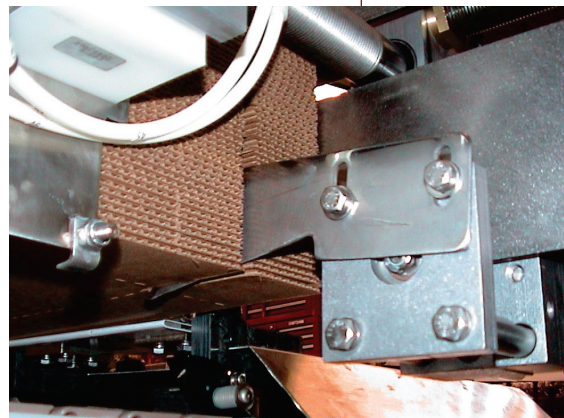

Figure 1.2 - Tray Blank Indexer properly adjusted

Call the Standard-Knapp Sales Department at
1-800-628-9565 for ordering information.

Standard-Knapp, Inc.
127 Main Street
Portland, CT 06480
1-800-628-9565
(fax) 860-342-0783
www.standard-knapp.com
info@standard-knapp.com

Standard Knapp Standard Knapp

an EMPLOYEE owned company

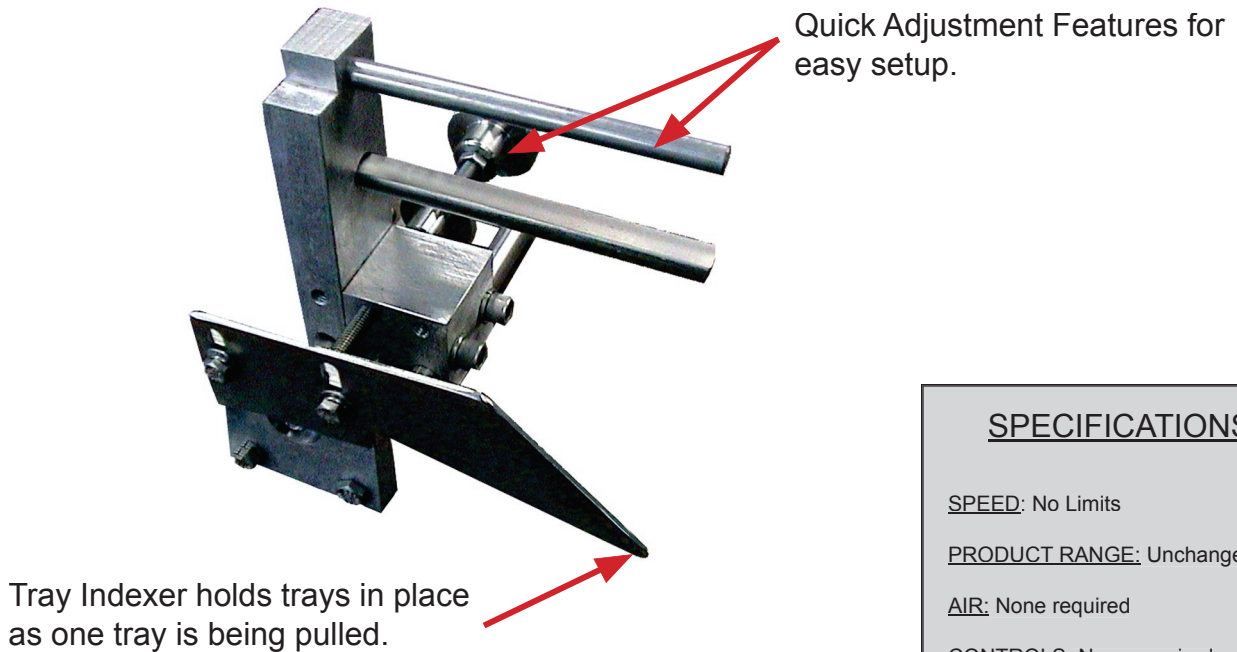

Figure 1.3 - Tray Blank Indexer Features

SPECIFICATIONS

SPEED: No Limits

PRODUCT RANGE: Unchanged

AIR: None required

CONTROLS: None required

POWER: None required

CONSTRUCTION: Stainless Steel

ESTIMATED WEIGHT: 30 lbs.

INSTALLATION: Standard-Knapp service recommended

TIME TO INSTALL: 4 hours

ADDITIONAL UPGRADE KITS AVAILABLE FOR YOUR 296 CONTINUUM

- DOUBLE BLANK DETECTOR
- TRAY TRANSPORT DEBRIS BRUSH
 - FILM SPINDLE SUPPORTS
- TRAY MAGAZINE BLANK RETAINER

Note: The Tray Blank Indexer Upgrade works well with the Debris Brush and Double Blank Detector Upgrades.