

# StandardKnapp StandardKnapp

an EMPLOYEE owned company

## TRAY TRANSPORT DOUBLE BLANK DETECTOR

**UPGRADE FOR:  
Model 296 Continuum  
Traypacker**

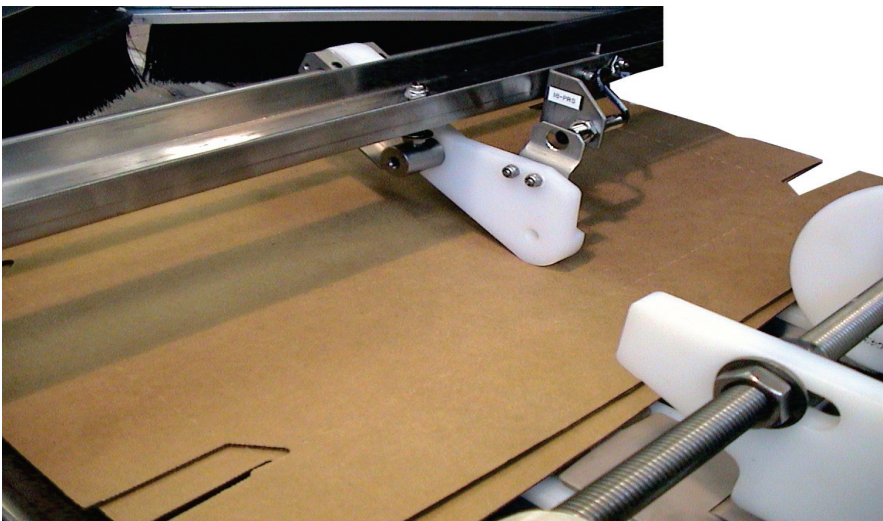

Figure 1.1 - Double Blank Detector detecting a Double Blank

Photo eye blocked as multiple blanks are detected.

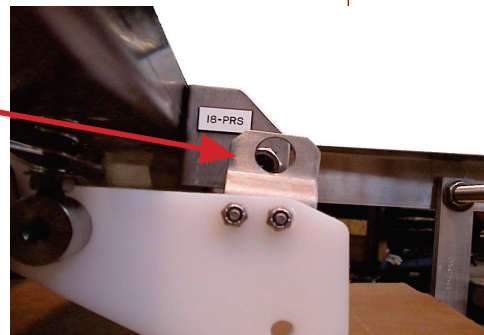

Figure 1.2 - Double blank causing detector to move upward and trip sensor

### Benefits

- Located immediately after tray tower, will detect thickness of double tray blanks.
- Brings machine to an end of cycle stop for easy removal of extra blank.
- Eliminates double tray jams in "hard to reach" product/tray merge area.
- Increase machine uptime and product output.

Call the Standard-Knapp Sales Department at  
1-800-628-9565 ext. 239 for ordering information.

Standard-Knapp, Inc.  
127 Main Street  
Portland, CT 06480  
1-800-628-9565  
(fax) 860-342-0783  
[www.standard-knapp.com](http://www.standard-knapp.com)  
[info@standard-knapp.com](mailto:info@standard-knapp.com)

# StandardKnapp StandardKnapp

an EMPLOYEE owned company

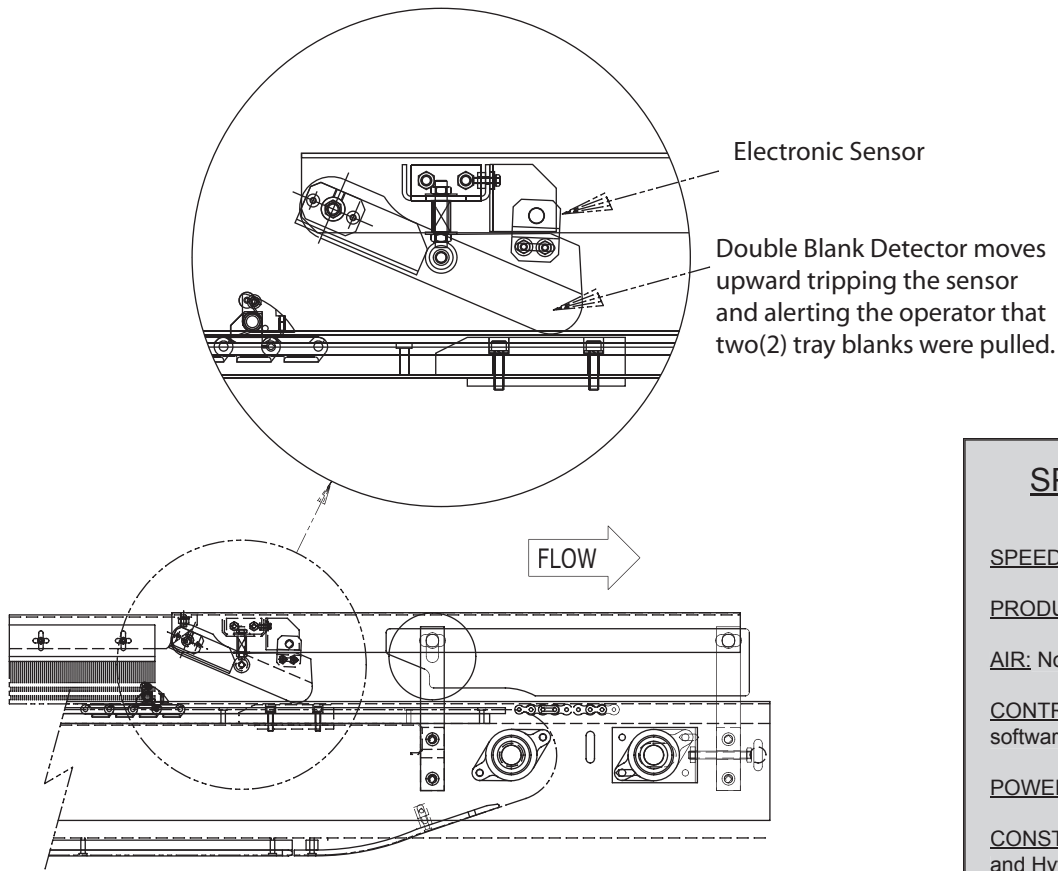

Figure 1.3 - Side View of Tray Transport Double Tray Blank Detector

## SPECIFICATIONS

SPEED: No Limits

PRODUCT RANGE: Unchanged

AIR: None required

CONTROLS: Photo eye and software logic included.

POWER: 24 Volt

CONSTRUCTION: Stainless Steel and Hyfax plastic

ESTIMATED WEIGHT: 10 lbs.

INSTALLATION: Standard-Knapp service recommended

TIME TO INSTALL: 3-4 hours

## ADDITIONAL UPGRADE KITS AVAILABLE FOR YOUR 296 CONTINUUM

- TRAY BLANK INDEXER
- TRAY TRANSPORT DEBRIS BRUSH
  - FILM SPINDLE SUPPORTS
- TRAY MAGAZINE BLANK RETAINER

*Note: The Double Blank Detection Upgrade works well with the Tray Transport Debris Brush Upgrade.*