

Standard Knapp Standard Knapp

an EMPLOYEE owned company

ADJUSTABLE COMPRESSION SECTION

UPGRADE FOR:
Model 202/263
Traymore

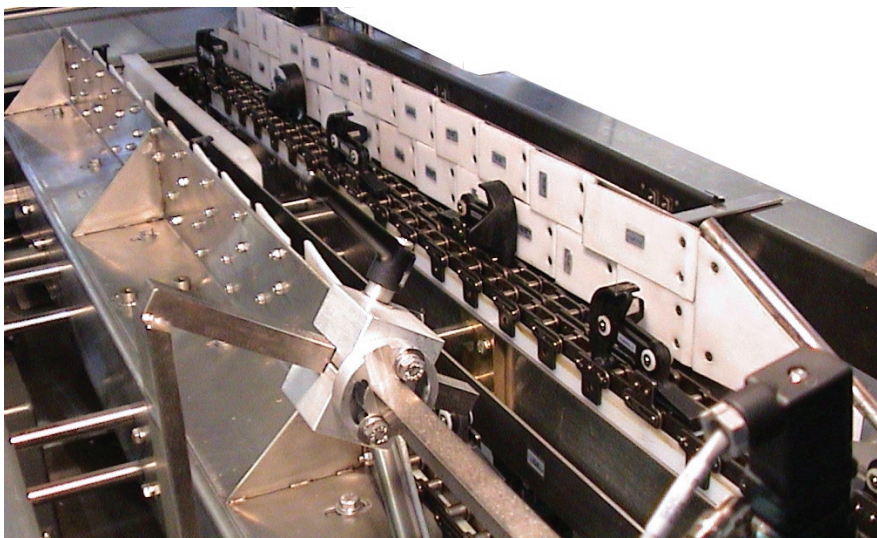

Figure 1.1 - Adjustable Compression Section

Benefits

- Quick Changeover.
- Square trays due to position of lugs at outermost corners during compression.
- Higher Reliability with Independent Clutch Protection and Reset.
- Ability to Handle a Wider Variety of Corrugate.

Adjustable Plastic Lugs for Quick Product Changeover.

Plastic Lugs positioned at the tray corners for enhanced control and product squaring.

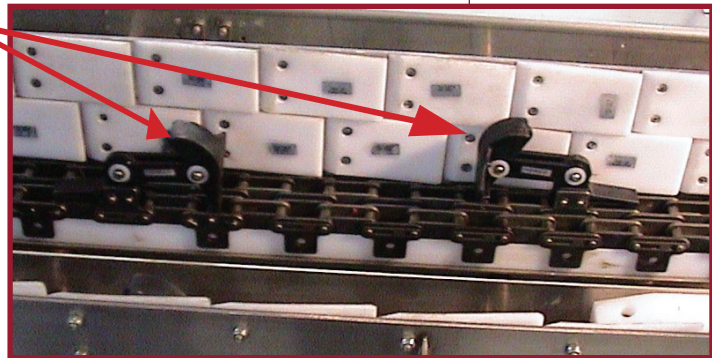

Figure 1.2 - Quick Adjusting Plastic Lugs

Call the Standard-Knapp Sales Department
at 1-800-628-9565 for ordering information.

Standard-Knapp, Inc.
127 Main Street
Portland, CT 06480
1-800-628-9565
(fax) 860-342-0783
www.standard-knapp.com
info@standard-knapp.com

Above photos were taken of a 296 Continuum Compression Section. Actual kit may differ.

Standard Knapp Standard Knapp

an EMPLOYEE owned company

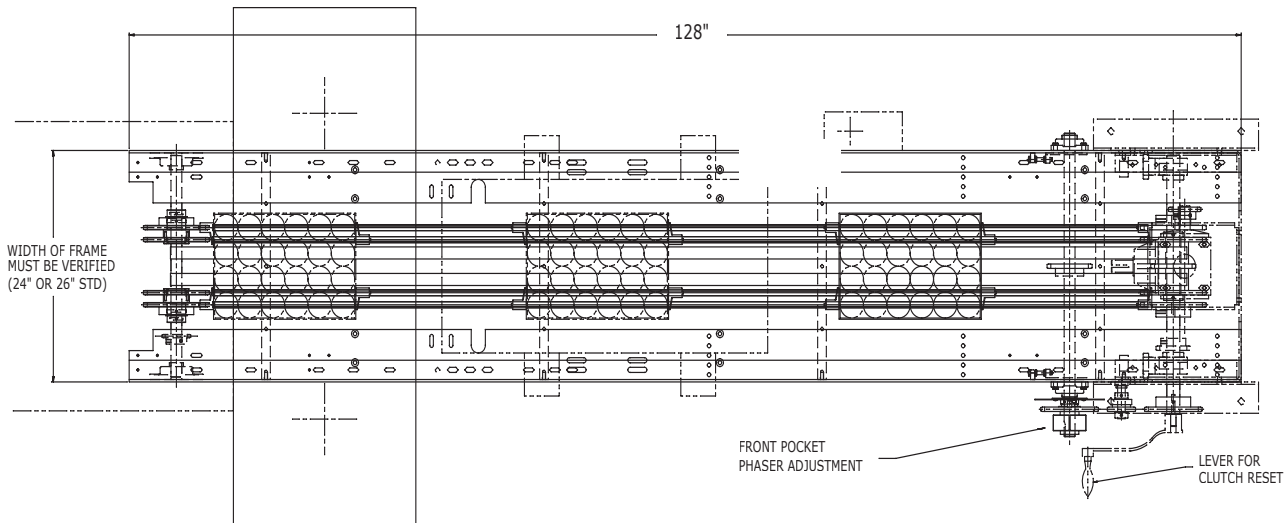

Figure 1.3 - Overhead View of New Compression Section

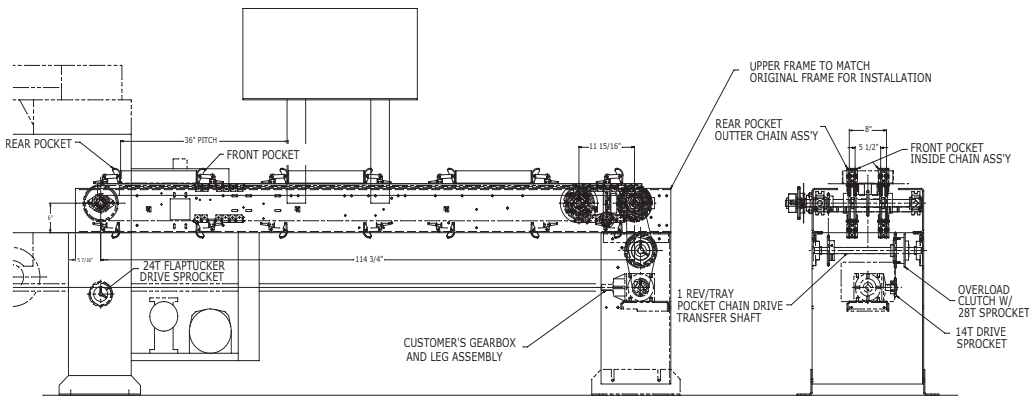

Figure 1.4 - Side View of New Compression Section

SPECIFICATIONS

SPEED: No Limits

PRODUCT RANGE: Unchanged

AIR: None required

CONTROLS: None required

POWER: None required

CONSTRUCTION:

ESTIMATED WEIGHT:

INSTALLATION: Standard-Knapp service recommended

TIME TO INSTALL:

Call the Standard-Knapp Sales Department
at 1-800-628-9565 for ordering information.