

Standard Knapp Standard Knapp

an EMPLOYEE owned company

SPLIT SPLINE SHAFT ASSEMBLY

**UPGRADE FOR:
189 Slitter/Sealer**

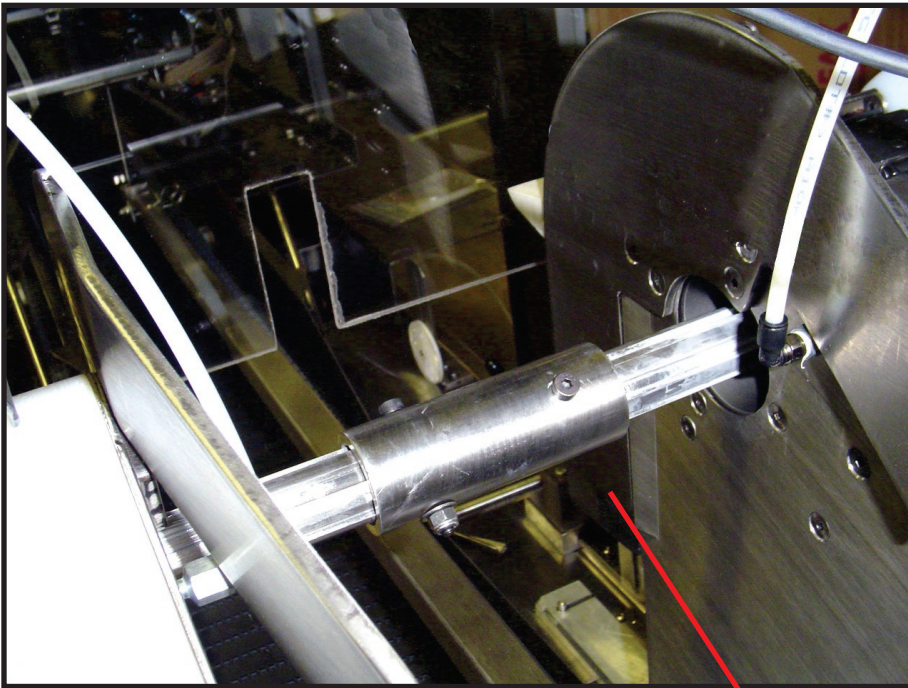

Figure 1.1 - Split Spline Shaft installed on Slitter/Sealer

Benefits

- Accurately and smoothly adjusts width of machine.
- Eliminates “jumping” of teeth when adjusting case width.
- Reduces Changeover Time
- Simple and quick installation

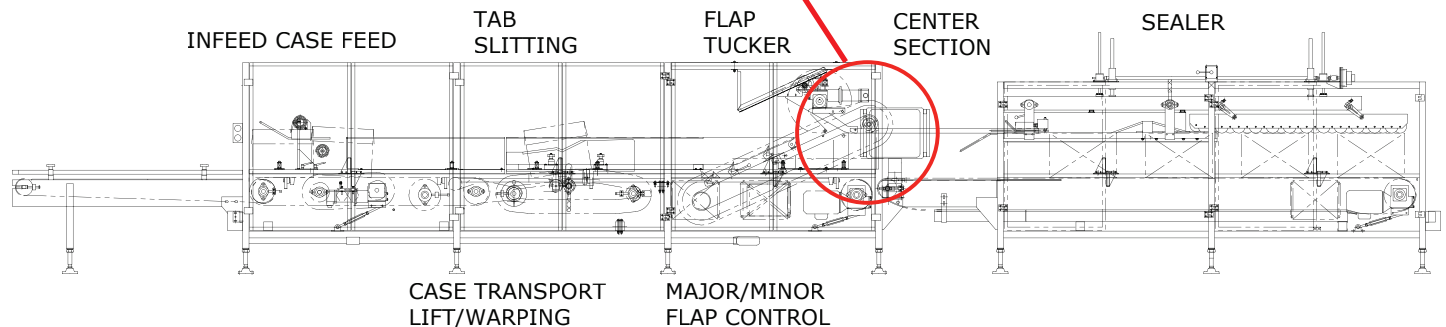

Figure 1.2 - Location of Split Spline Shaft on Slitter/Sealer

Call the Standard-Knapp Sales Department at 1-800-628-9565 ext. 239 for ordering information.

Standard-Knapp, Inc.
127 Main Street
Portland, CT 06480
1-800-628-9565
(fax) 860-342-0783
www.standard-knapp.com
info@standard-knapp.com

Standard Knapp Standard Knapp

an EMPLOYEE owned company

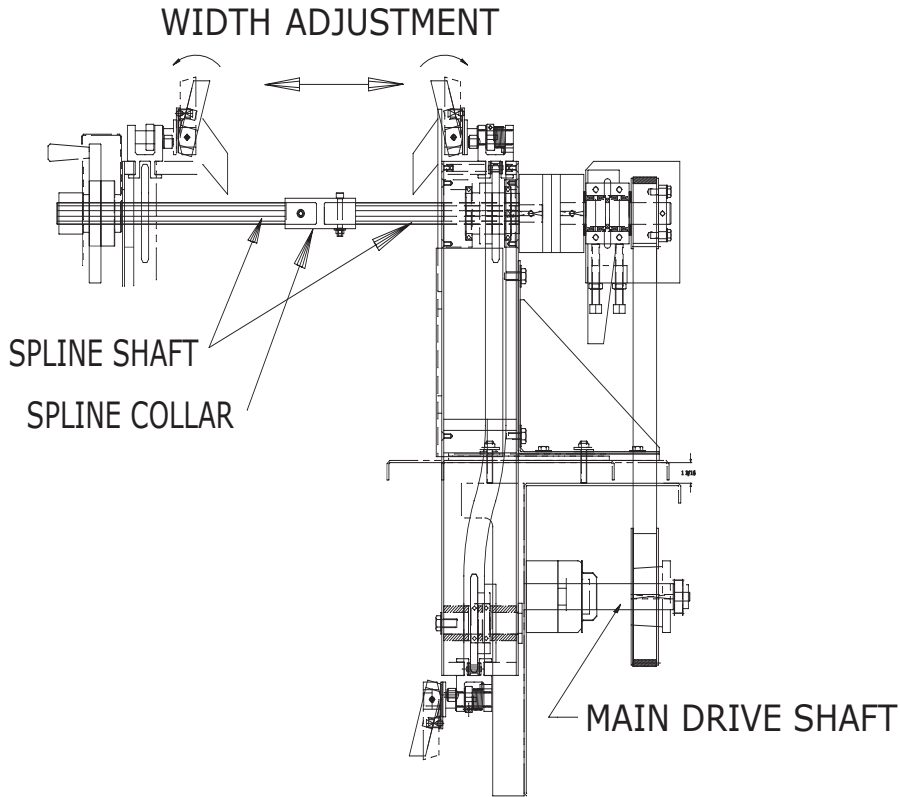

Figure 1.3 - Split Spline Shaft shown with Spline Collar

SPECIFICATIONS

SPEED: No Limits

PRODUCT RANGE: Unchanged

AIR: None required

CONTROLS: None required

POWER: None required

ADDITIONAL UPGRADE KITS AVAILABLE FOR YOUR 189 SLITTER/SEALER

- ARTICULATING TEAR DROPS