

Standard Knapp Standard Knapp

an EMPLOYEE owned company

ARTICULATING TEAR-DROPS

**UPGRADE FOR:
Model 189 Slitter-Sealer
Kit# 189P90133**

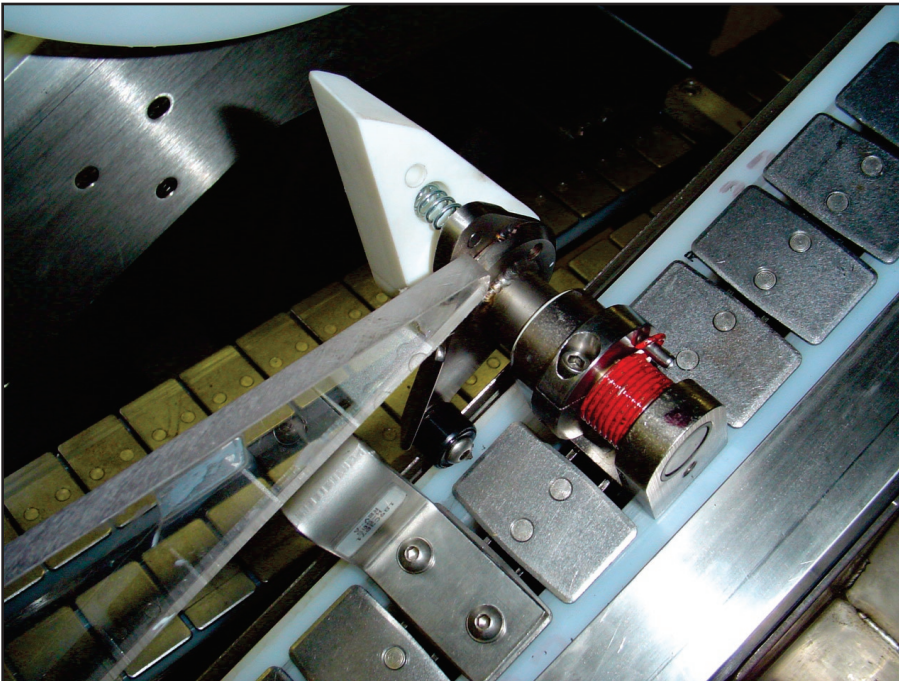

Figure 1.1 - Articulating Tear-Drop installed on Slitter-Sealer

Benefits

- Better positioning of tear-drops resulting in positive lift of minor case flaps.
- Increased efficiency on narrow cases.
- Eliminates missed flap occurrences.
- Reduces machine downtime due to warped case material.
- Better case guide width control at knife section.



Figure 1.2 - Spring loaded tear-drop positioned to positively fold minor flaps.

Call the Standard-Knapp Sales Department at
1-800-628-9565 ext. 239 for ordering information.

Standard-Knapp, Inc.
127 Main Street
Portland, CT 06480
1-800-628-9565
(fax) 860-342-0783
www.standard-knapp.com
info@standard-knapp.com

Standard Knapp Standard Knapp

an EMPLOYEE owned company

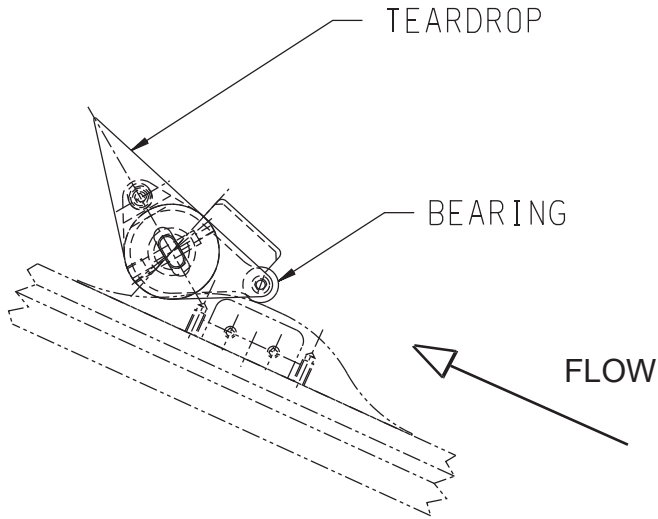

Figure 1.3 - Side view of Articulating Tear Drop shown pivoting forward

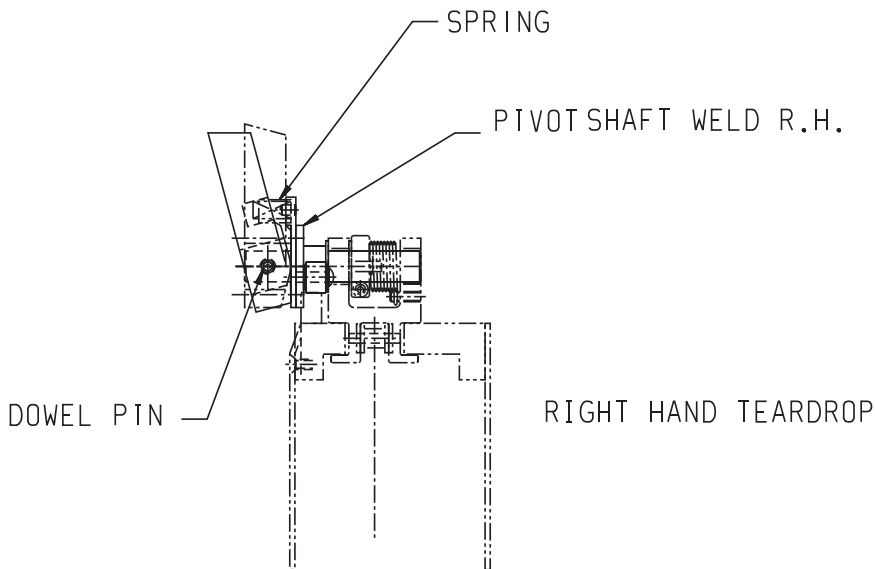

Figure 1.4 - Articulating Tear Drop shown pivoting inward

SPECIFICATIONS

SPEED: No Limits

PRODUCT RANGE: Unchanged

AIR: None required

CONTROLS: None required

POWER: None required

CONSTRUCTION: Stainless Steel

ESTIMATED WEIGHT: 1 lb. each

INSTALLATION: Standard-Knapp
service recommended

TIME TO INSTALL: 6 hours

ADDITIONAL UPGRADE KITS AVAILABLE FOR YOUR 189 SLITTER-SEALER

• SPLIT SHAFT ASSEMBLY