

PakMore™



***Continuous Motion,
Soft Placement
Case Packer***



StandardKnapp

PakMore™ Continuous Motion Case Packer

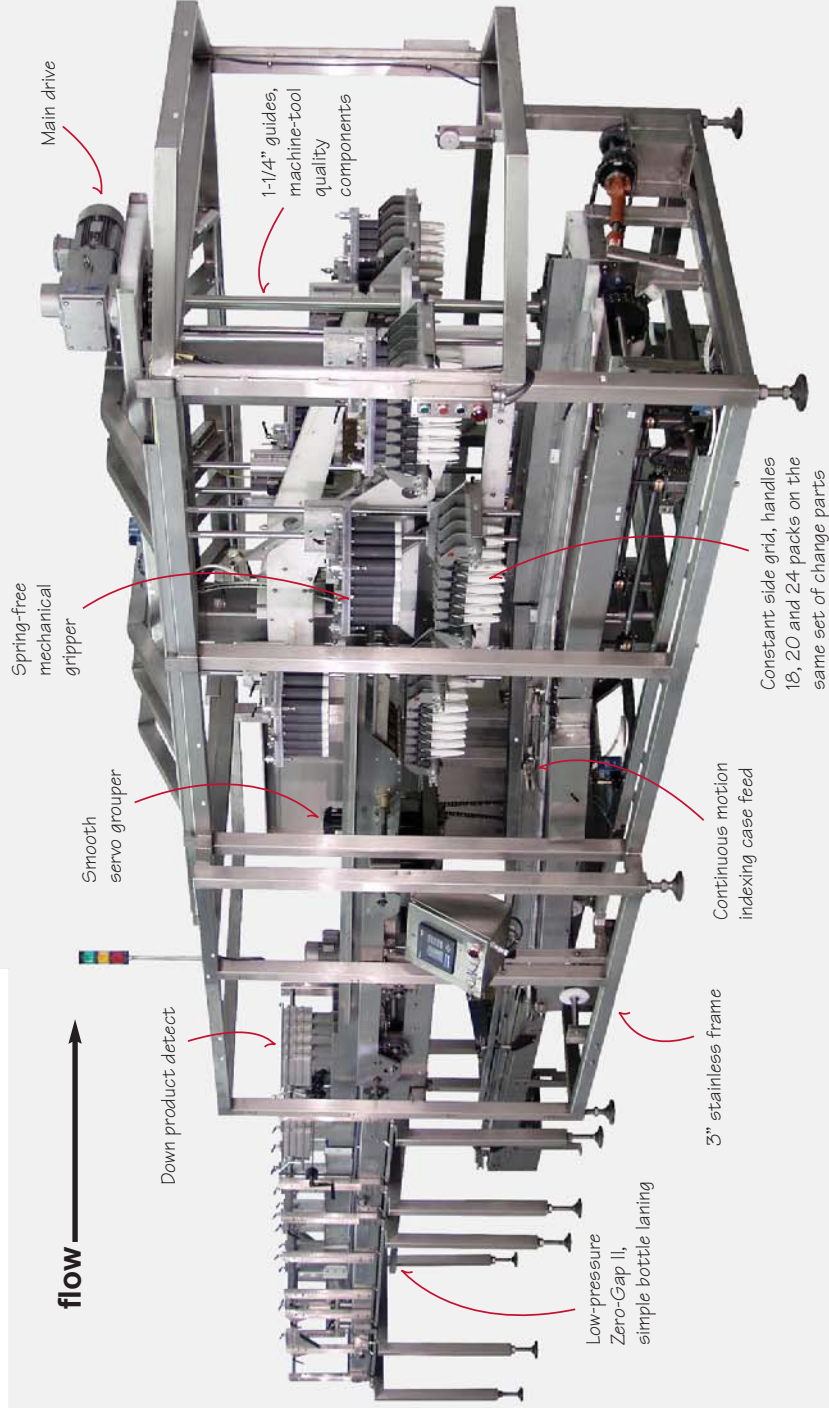

- PakMore™ Benefits**
- **High reliability** – designed for 24/7 operation at 50 or 75 CPM
 - **Simple operation** and intuitive operator interface
 - **Smart innovation** with automatic fault recovery features
 - **Small footprint** with either “inline” or “peninsula” layout
 - **Easy walk-by maintenance** – all components are visible and accessible
 - **Flexible and adaptable** to future applications
 - **Quality fit and finish** – robust stainless construction

“The new case packer provides easier handling of the containers with less bottle breakage, less label damage and higher speed packing.”

– A Major U.S. Beverage Distributor



Standard-Knapp PakMore™ shown in production.

PakMore™ Floor Plan

Inline layout shown integrated with optional tab-lock slitter/sealer

Synchronized via servo

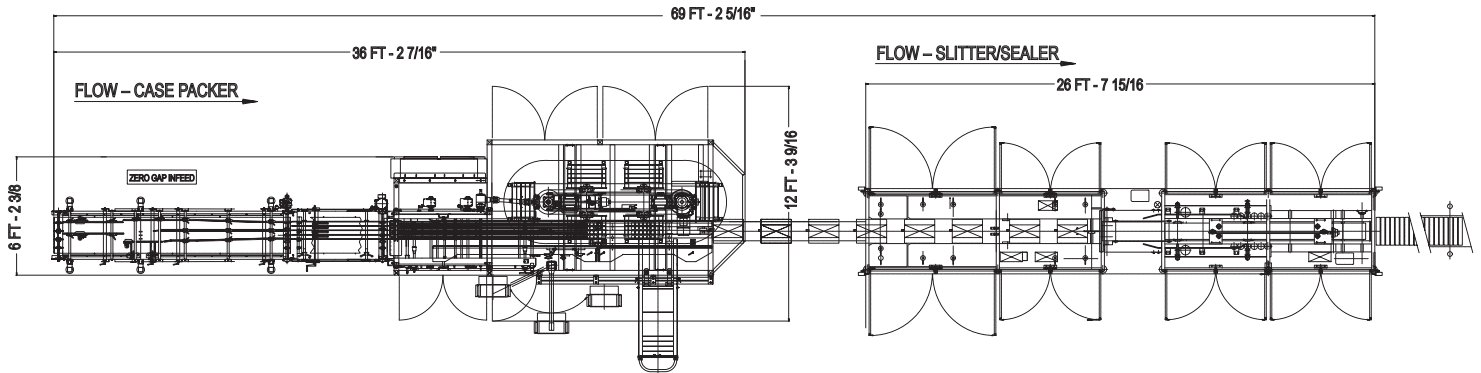

Peninsula layout, with slitter/sealer

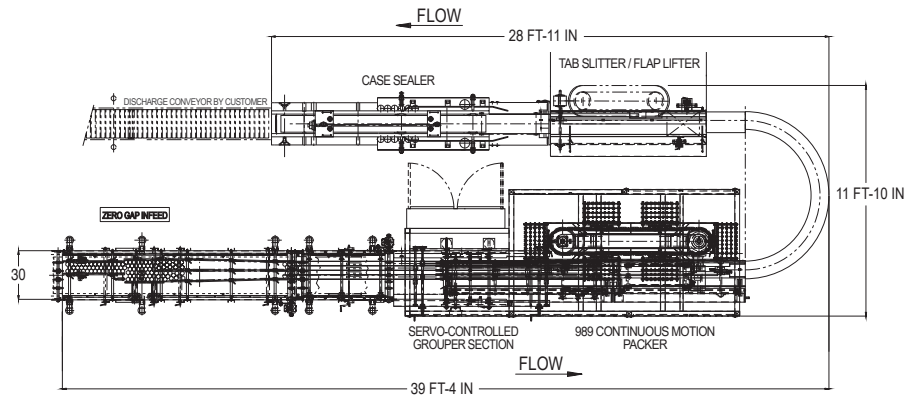

Specifications*

Model: 989

Speeds: 50, 75 CPM

Electrical Supply: 460V

Air Supply: 80 psi with 3/4 NPT

Controls: Allen-Bradley ControlLogix

Servo Drives: Allen-Bradley Ultra 3000 or Kinetix 6000

Interface: Allen-Bradley PanelView

Motors:

Main Drive: 5 HP

Zero Gap Drive: 2 HP

Infeed Drive: 1 HP

Groupers: Servo

** Standard-Knapp is committed to continuous product improvement. Specifications are subject to change without notice.*



Standard Knapp

STANDARD-KNAPP, INC.

63 Pickering Street, Portland, CT 06480 U.S.A.

SALES PHONE: (860) 342-1100, ext. 239

SALES FAX: (860) 342-1557

EMAIL: info@standard-knapp.com

WEB SITE: www.standard-knapp.com